

גרפיקה ממוחשבת תש"ע א' – ליאור שפירא – שיעור 3

Modeling Transformations

Based on:

Thomas Funkhouser

Princeton University

COS 426, Fall 2000

Modeling Transformations

- Transformation (definition)
 - A qualitative change
 - A function that changes the position or direction of the axes of a coordinate system
 - The act of changing in form or shape or appearance
- Specify transformations for objects
 - Allows definitions of objects in own coordinate systems
 - Allows use of object definition multiple times in a scene

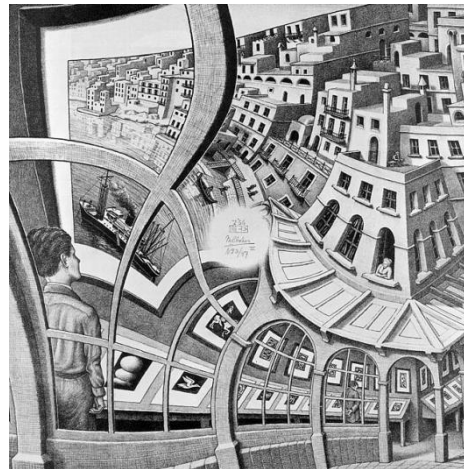

Overview

- 2D Transformations
 - Basic 2D transformations
 - Matrix representation
 - Matrix composition
- 3D Transformations
 - Basic 3D transformations
 - Same as 2D
- Transformation Hierarchies
 - Scene graphs
 - Ray casting

2D Modeling Transformations

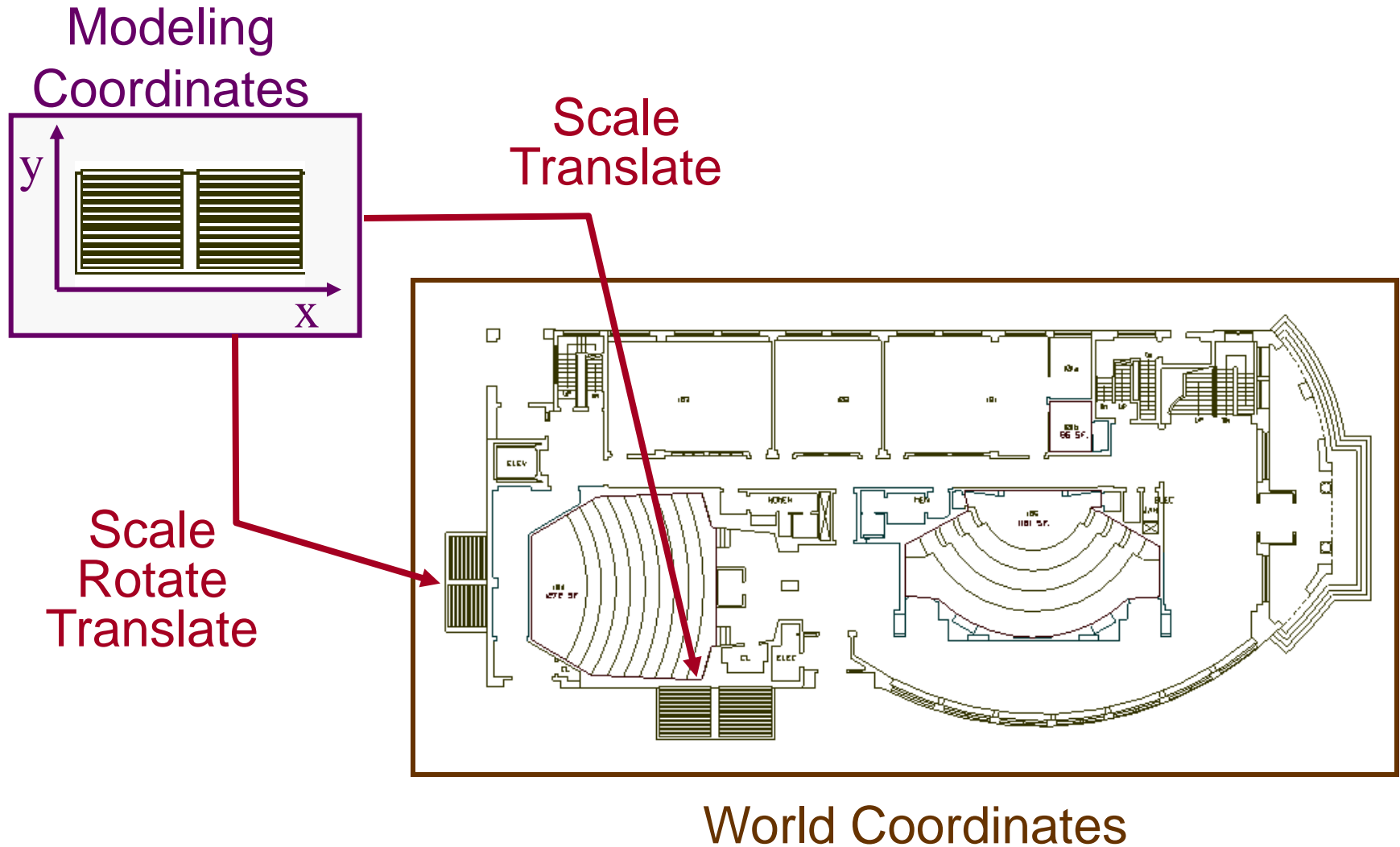

2D Modeling Transformations

Modeling
Coordinates



Again?

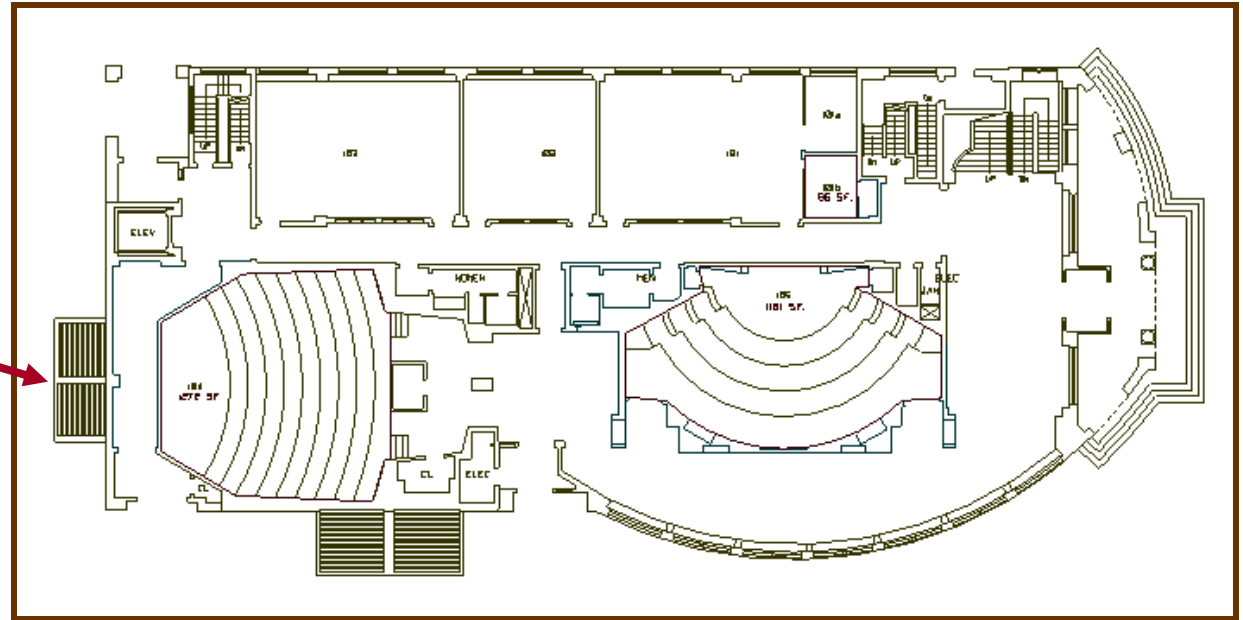

World Coordinates

2D Modeling Transformations

Modeling
Coordinates

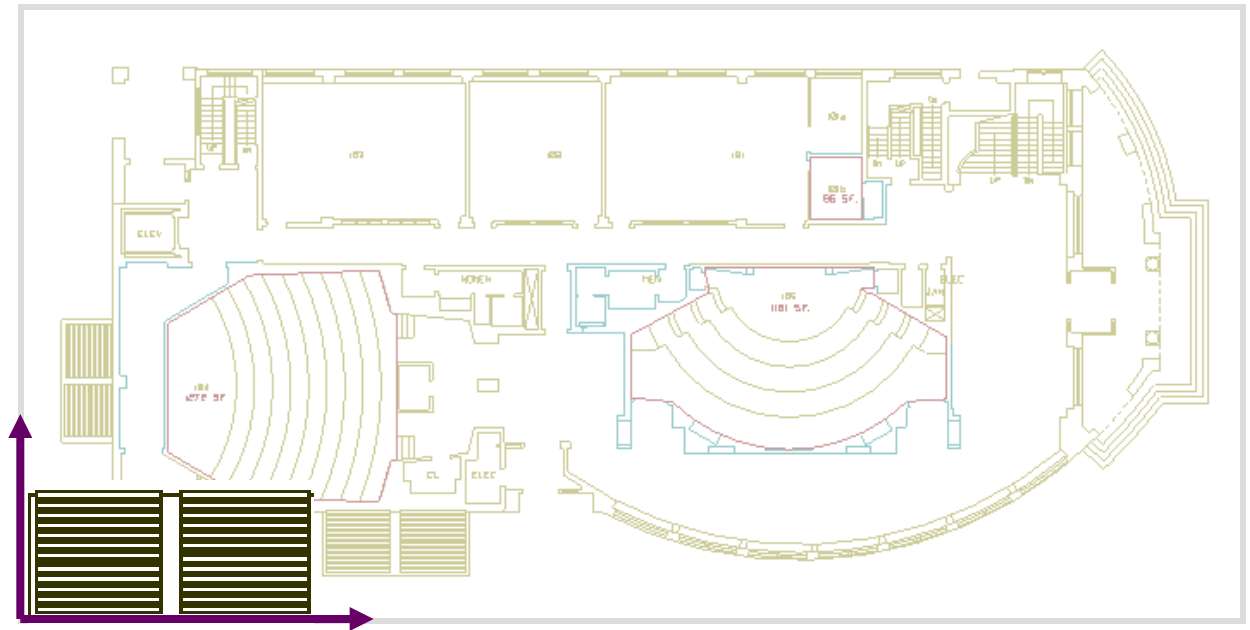
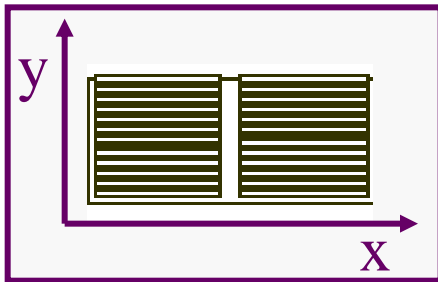

2D Modeling Transformations

Modeling
Coordinates

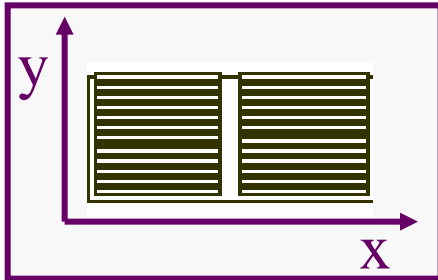

Scale .3, .3

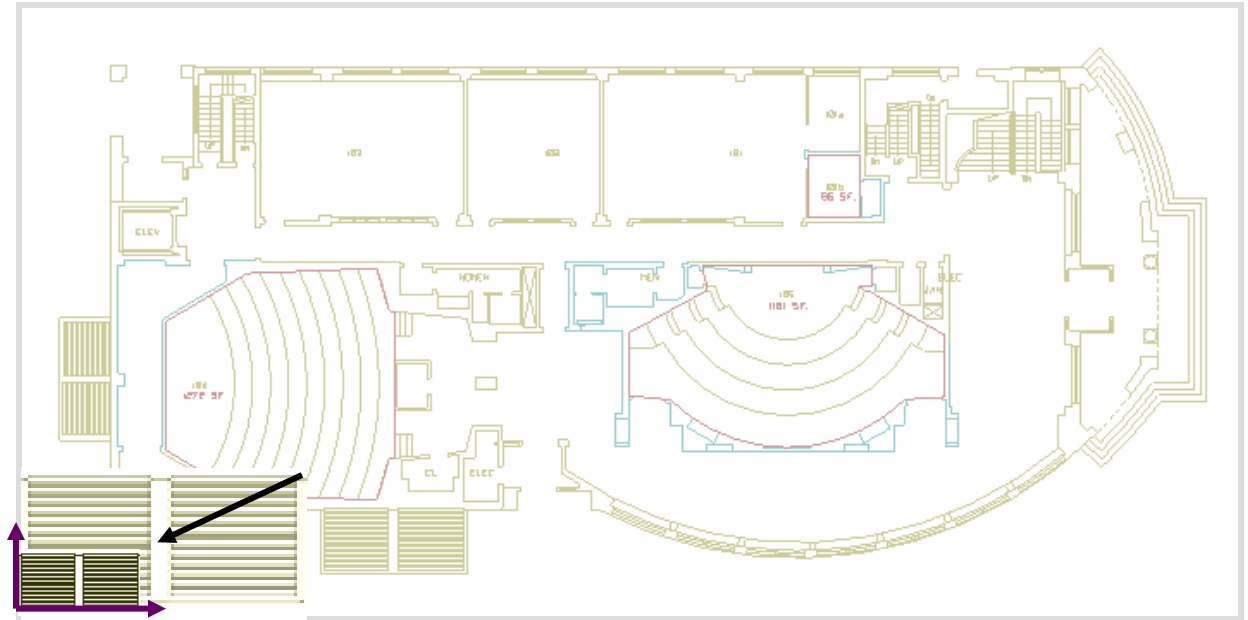

2D Modeling Transformations

Modeling
Coordinates

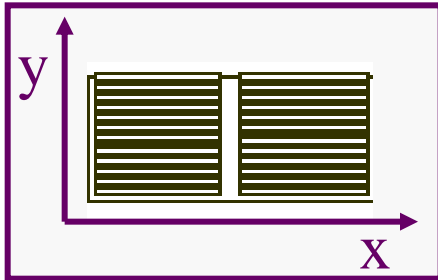

Scale .3, .3
Rotate -90

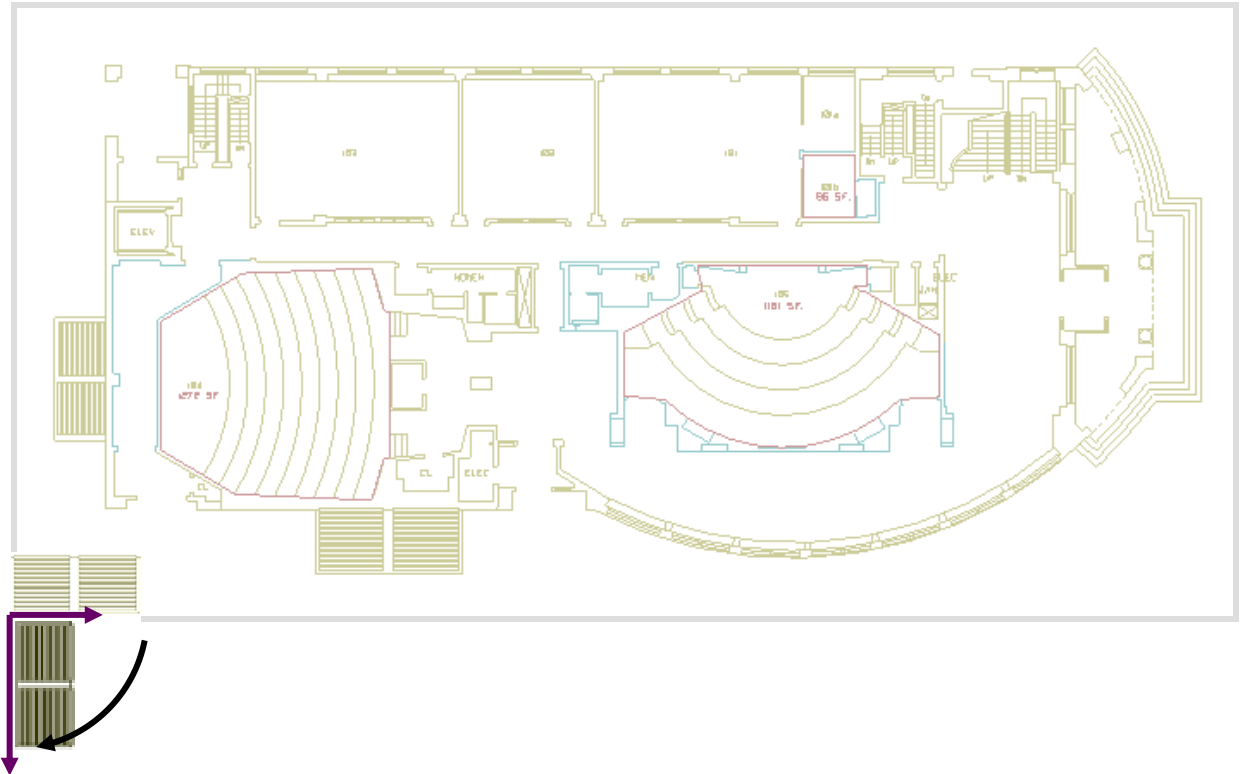

2D Modeling Transformations

Modeling
Coordinates

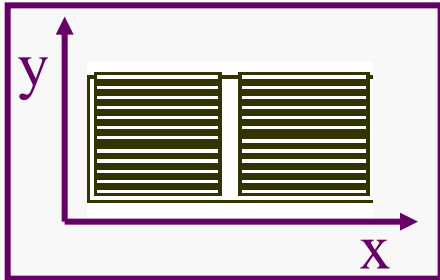

Scale .3, .3
Rotate -90
Translate 5, 3

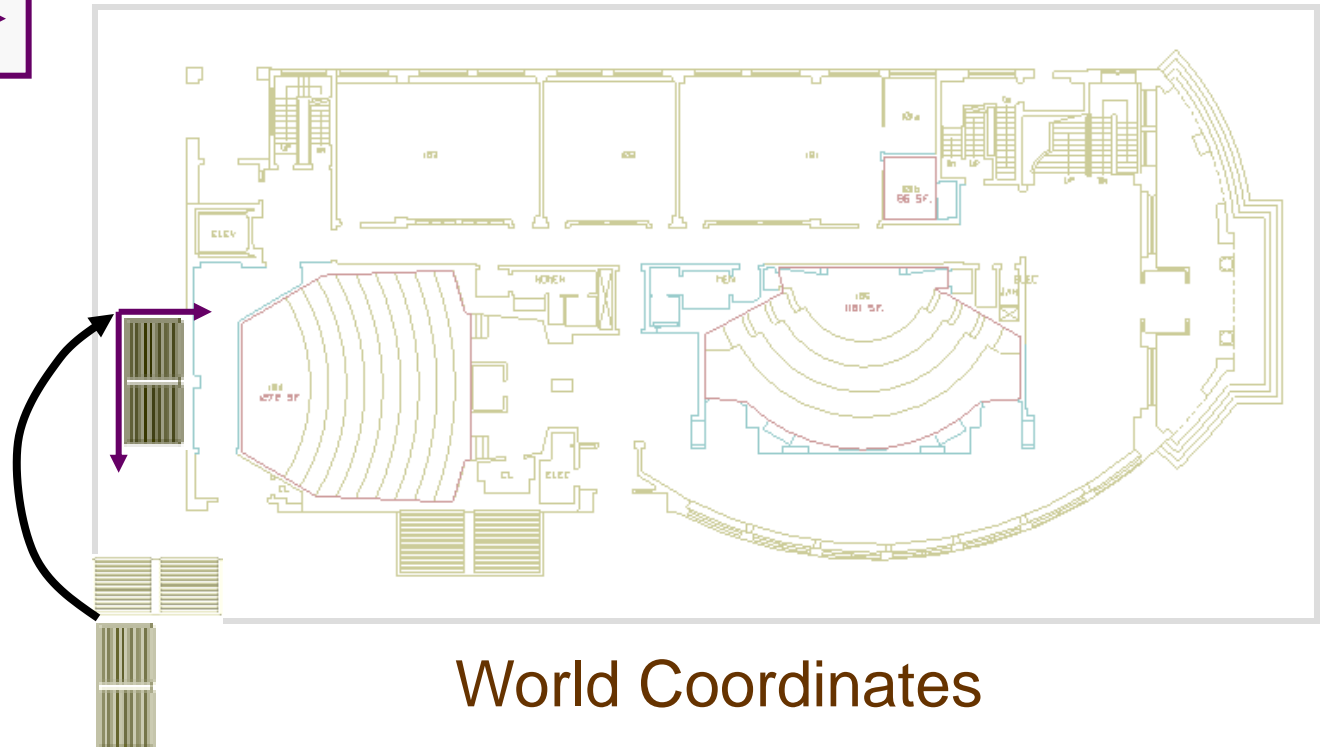

World Coordinates

Basic 2D Transformations

- Translation:
 - $x' = x + tx$
 - $y' = y + ty$
- Scale:
 - $x' = x * sx$
 - $y' = y * sy$
- Rotation:
 - $x' = x * \cos\Theta - y * \sin\Theta$
 - $y' = x * \sin\Theta + y * \cos\Theta$
- Shear:
 - $x' = x + hx * y$
 - $y' = y + hy * x$

Basic 2D Transformations

- Translation:

- $x' = x + tx$
- $y' = y + ty$

- Scale:

- $x' = x * sx$
- $y' = y * sy$

- Shear:

- $x' = x + hx*y$
- $y' = y + hy*x$

- Rotation:

- $x' = x*\cos\Theta - y*\sin\Theta$
- $y' = x*\sin\Theta + y*\cos\Theta$

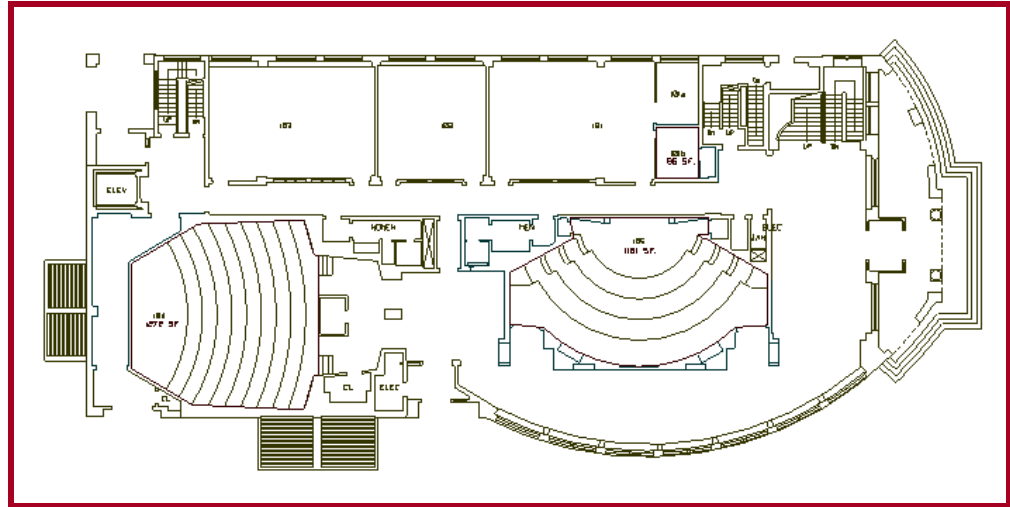

Transformations
can be combined
(with simple algebra)

Basic 2D Transformations

- Translation:

- $x' = x + tx$
- $y' = y + ty$

- Scale:

- $x' = x * sx$
- $y' = y * sy$

- Shear:

- $x' = x + hx*y$
- $y' = y + hy*x$

- Rotation:

- $x' = x*\cos\Theta - y*\sin\Theta$
- $y' = x*\sin\Theta + y*\cos\Theta$

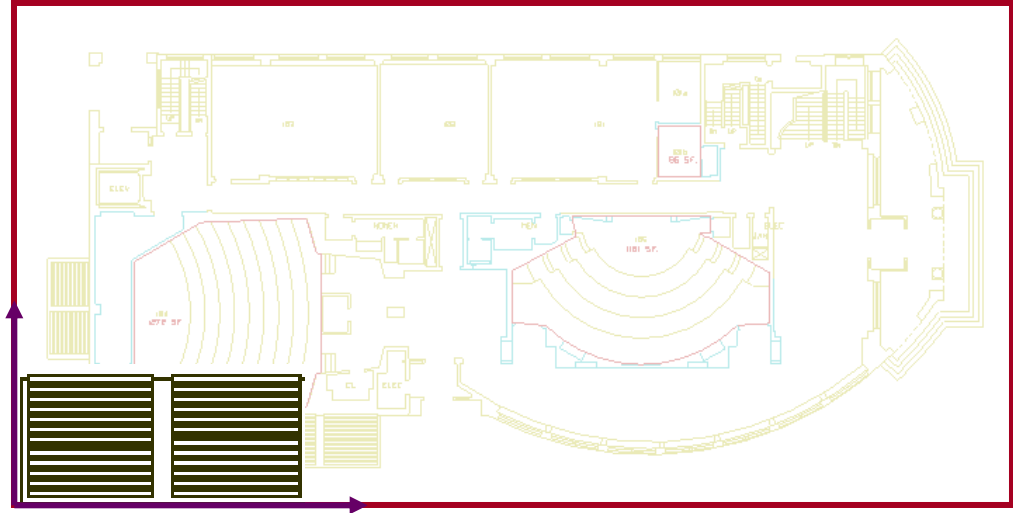

Basic 2D Transformations

- Translation:

- $x' = x + tx$
- $y' = y + ty$

- Scale:

- $x' = x * sx$
- $y' = y * sy$

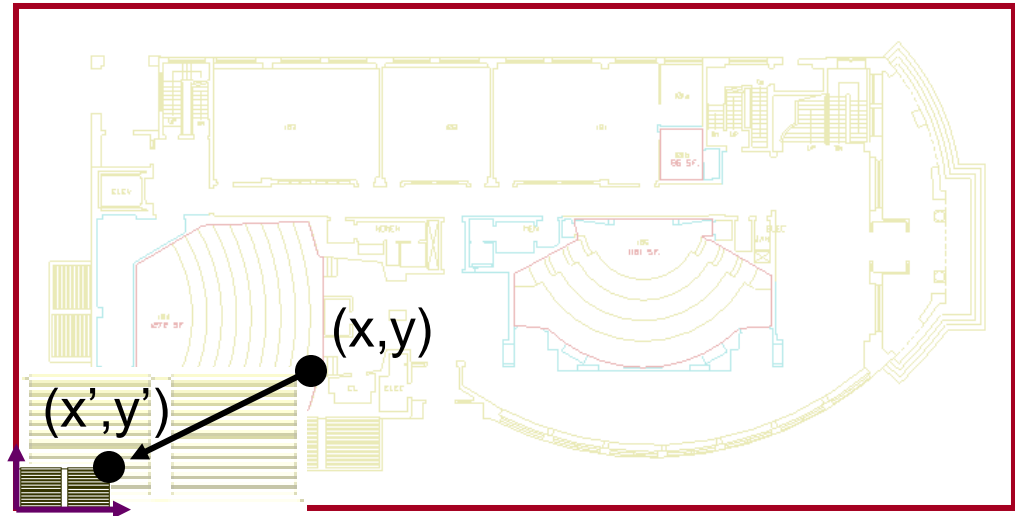

- Shear:

- $x' = x + hx*y$
- $y' = y + hy*x$

$$\begin{aligned} x' &= x * sx \\ y' &= y * sy \end{aligned}$$

- Rotation:

- $x' = x * \cos\Theta - y * \sin\Theta$
- $y' = x * \sin\Theta + y * \cos\Theta$

Basic 2D Transformations

- Translation:

- $x' = x + tx$
- $y' = y + ty$

- Scale:

- $x' = x * sx$
- $y' = y * sy$

- Shear:

- $x' = x + hx*y$
- $y' = y + hy*x$

- Rotation:

- $x' = x*\cos\Theta - y*\sin\Theta$
- $y' = x*\sin\Theta + y*\cos\Theta$

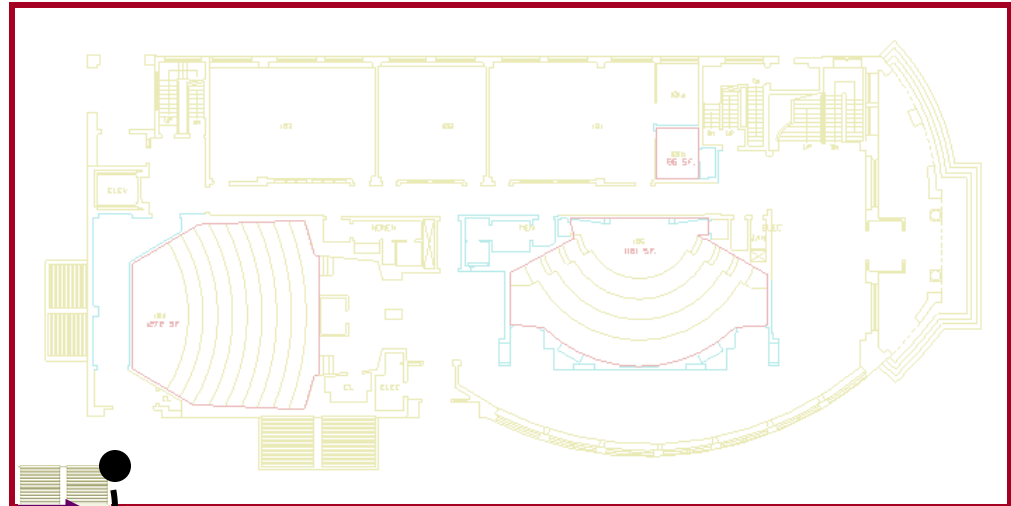

$$\begin{aligned}x' &= (x*sx)*\cos\Theta - (y*sy)*\sin\Theta \\y' &= (x*sx)*\sin\Theta + (y*sy)*\cos\Theta\end{aligned}$$

Basic 2D Transformations

- Translation:

- $x' = x + tx$
- $y' = y + ty$

- Scale:

- $x' = x * sx$
- $y' = y * sy$

- Shear:

- $x' = x + hx*y$
- $y' = y + hy*x$

- Rotation:

- $x' = x*\cos\Theta - y*\sin\Theta$
- $y' = x*\sin\Theta + y*\cos\Theta$

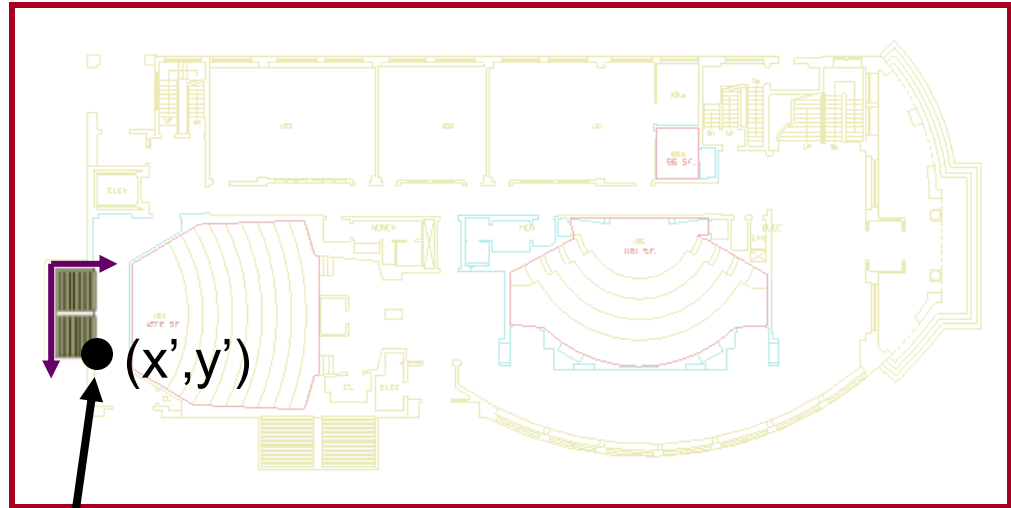

$$\begin{aligned}x' &= ((x*sx)*\cos\Theta - (y*sy)*\sin\Theta) + tx \\y' &= ((x*sx)*\sin\Theta + (y*sy)*\cos\Theta) + ty\end{aligned}$$

Basic 2D Transformations

- Translation:

- $x' = x + tx$
- $y' = y + ty$

- Scale:

- $x' = x * sx$
- $y' = y * sy$

- Shear:

- $x' = x + hx*y$
- $y' = y + hy*x$

- Rotation:

- $x' = x*\cos\Theta - y*\sin\Theta$
- $y' = x*\sin\Theta + y*\cos\Theta$

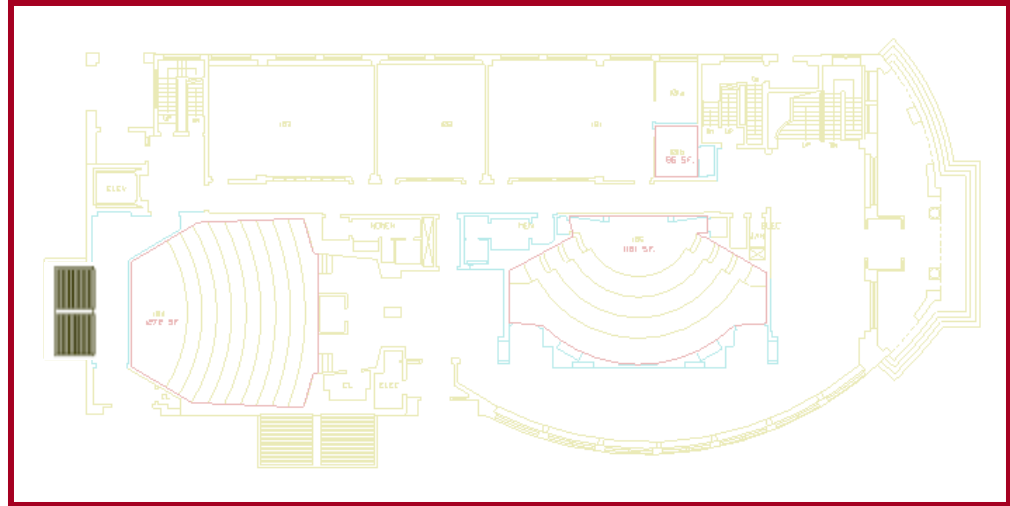

$$\begin{aligned}x' &= ((x*sx)*\cos\Theta - (y*sy)*\sin\Theta) + tx \\y' &= ((x*sx)*\sin\Theta + (y*sy)*\cos\Theta) + ty\end{aligned}$$

Compositions of Transformations

- **Rigid** transformations
 - **Translation + Rotation (distance preserving)**
- **Similarity** transformations
 - **Translation + Rotation + Uniform scale (angle preserving)**
- **Affine** transformations
 - **Translation + Rotation + Scale + Shear (preserve parallel lines)**

Overview

- 2D Transformations
 - Basic 2D transformations
 - Matrix representation
 - Matrix composition
- 3D Transformations
 - Basic 3D transformations
 - Same as 2D
- Transformation Hierarchies
 - Scene graphs
 - Ray casting

Matrix Representation

- We can represent a 2D transformation by a matrix

$$\begin{bmatrix} a & b \\ c & d \end{bmatrix}$$

- Multiplying a matrix by a column vector corresponds to applying the transformation to a point

$$\begin{bmatrix} x' \\ y' \end{bmatrix} = \begin{bmatrix} a & b \\ c & d \end{bmatrix} \begin{bmatrix} x \\ y \end{bmatrix}$$

$$x' = ax + by$$

$$y' = cx + dy$$

Matrix Representation

- Transformations can be combined by matrix multiplication

$$\begin{bmatrix} x' \\ y' \end{bmatrix} = \begin{bmatrix} a & b \\ c & d \end{bmatrix} \begin{bmatrix} e & f \\ g & h \end{bmatrix} \begin{bmatrix} i & j \\ k & l \end{bmatrix} \begin{bmatrix} x \\ y \end{bmatrix}$$

Matrices are a convenient and efficient way to represent a sequence of transformations

2x2 Matrices

- What types of transformations can be represented with a 2x2 matrix?

2D Identity?

$$\begin{aligned}x' &= x \\ y' &= y\end{aligned}$$

$$\begin{bmatrix} x' \\ y' \end{bmatrix} = \begin{bmatrix} 1 & 0 \\ 0 & 1 \end{bmatrix} \begin{bmatrix} x \\ y \end{bmatrix}$$

2D Scale around (0,0)?

$$\begin{aligned}x' &= sx * x \\ y' &= sy * y\end{aligned}$$

$$\begin{bmatrix} x' \\ y' \end{bmatrix} = \begin{bmatrix} sx & 0 \\ 0 & sy \end{bmatrix} \begin{bmatrix} x \\ y \end{bmatrix}$$

2x2 Matrices

- What types of transformations can be represented with a 2x2 matrix?

2D Rotate around (0,0)?

$$\begin{aligned}x' &= \cos \Theta * x - \sin \Theta * y \\y' &= \sin \Theta * x + \cos \Theta * y\end{aligned}$$

$$\begin{bmatrix} x' \\ y' \end{bmatrix} = \begin{bmatrix} \cos \Theta & -\sin \Theta \\ \sin \Theta & \cos \Theta \end{bmatrix} \begin{bmatrix} x \\ y \end{bmatrix}$$

2D Shear?

$$\begin{aligned}x' &= x + shx * y \\y' &= shy * x + y\end{aligned}$$

$$\begin{bmatrix} x' \\ y' \end{bmatrix} = \begin{bmatrix} 1 & shx \\ shy & 1 \end{bmatrix} \begin{bmatrix} x \\ y \end{bmatrix}$$

2x2 Matrices

- What types of transformations can be represented with a 2x2 matrix?

2D Mirror over Y axis?

$$\begin{aligned}x' &= -x \\ y' &= y\end{aligned}$$

$$\begin{bmatrix} x' \\ y' \end{bmatrix} = \begin{bmatrix} -1 & 0 \\ 0 & 1 \end{bmatrix} \begin{bmatrix} x \\ y \end{bmatrix}$$

2D Mirror over (0,0)?

$$\begin{aligned}x' &= -x \\ y' &= -y\end{aligned}$$

$$\begin{bmatrix} x' \\ y' \end{bmatrix} = \begin{bmatrix} -1 & 0 \\ 0 & -1 \end{bmatrix} \begin{bmatrix} x \\ y \end{bmatrix}$$

2x2 Matrices

- What types of transformations can be represented with a 2x2 matrix?

2D Translation?

$$x' = x + tx$$

$$y' = y + ty$$

NO!

Only linear 2D transformations
can be represented with a 2x2 matrix

Linear Transformations

- Linear transformations are combinations of ...

- Scale,
- Rotation,
- Shear, and
- Mirror

$$\begin{bmatrix} x' \\ y' \end{bmatrix} = \begin{bmatrix} a & b \\ c & d \end{bmatrix} \begin{bmatrix} x \\ y \end{bmatrix}$$

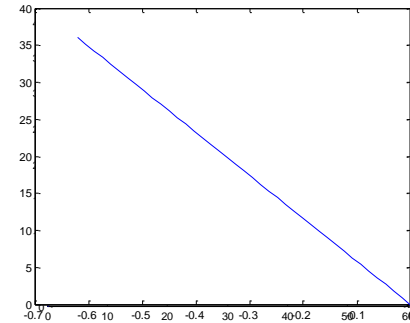

- Properties of linear transformations:

- Satisfies: $T(s_1\mathbf{p}_1 + s_2\mathbf{p}_2) = s_1T(\mathbf{p}_1) + s_2T(\mathbf{p}_2)$

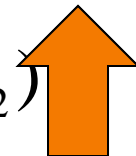

Rotate

- Origin maps to origin $\rightarrow T(0,0) = (0,0)$
- Lines map to lines $\rightarrow y = 1.5x$
- Parallel lines remain parallel
- Ratios are preserved
- Closed under composition

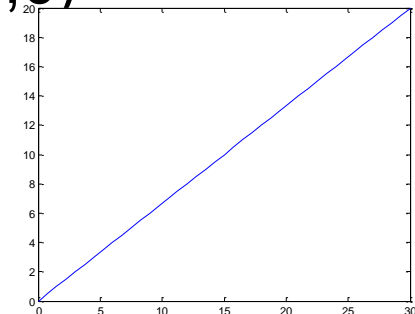

2D Translation

- 2D translation can be represented by a 3x3 matrix
 - Point represented with homogeneous coordinates

$$\begin{aligned}x' &= x + tx \\ y' &= y + ty\end{aligned}$$

$$\begin{bmatrix} x' \\ y' \\ 1 \end{bmatrix} = \begin{bmatrix} 1 & 0 & tx \\ 0 & 1 & ty \\ 0 & 0 & 1 \end{bmatrix} \begin{bmatrix} x \\ y \\ 1 \end{bmatrix}$$

Homogeneous Coordinates

- Add a 3rd coordinate to every 2D point
 - (x, y, w) represents a point at location $(x/w, y/w)$
 - $(x, y, 0)$ represents a point at infinity
 - $(0, 0, 0)$ is not allowed

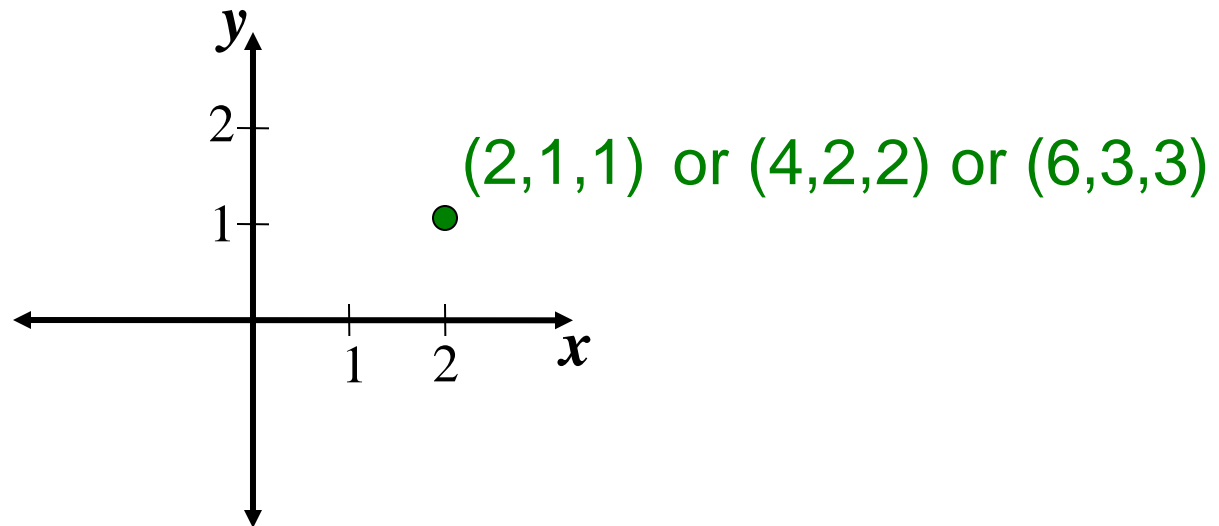

Convenient coordinate system to represent many useful transformations

Basic 2D Transformations

- Basic 2D transformations as 3x3 matrices

$$\begin{bmatrix} x' \\ y' \\ 1 \end{bmatrix} = \begin{bmatrix} 1 & 0 & tx \\ 0 & 1 & ty \\ 0 & 0 & 1 \end{bmatrix} \begin{bmatrix} x \\ y \\ 1 \end{bmatrix}$$

Translate

$$\begin{bmatrix} x' \\ y' \\ 1 \end{bmatrix} = \begin{bmatrix} sx & 0 & 0 \\ 0 & sy & 0 \\ 0 & 0 & 1 \end{bmatrix} \begin{bmatrix} x \\ y \\ 1 \end{bmatrix}$$

Scale

$$\begin{bmatrix} x' \\ y' \\ 1 \end{bmatrix} = \begin{bmatrix} \cos \Theta & -\sin \Theta & 0 \\ \sin \Theta & \cos \Theta & 0 \\ 0 & 0 & 1 \end{bmatrix} \begin{bmatrix} x \\ y \\ 1 \end{bmatrix}$$

Rotate

$$\begin{bmatrix} x' \\ y' \\ 1 \end{bmatrix} = \begin{bmatrix} 1 & shx & 0 \\ shy & 1 & 0 \\ 0 & 0 & 1 \end{bmatrix} \begin{bmatrix} x \\ y \\ 1 \end{bmatrix}$$

Shear

Affine Transformations

- Affine transformations are combinations of ...
 - Linear transformations, and
 - Translations

$$\begin{bmatrix} x' \\ y' \\ w \end{bmatrix} = \begin{bmatrix} a & b & c \\ d & e & f \\ 0 & 0 & 1 \end{bmatrix} \begin{bmatrix} x \\ y \\ w \end{bmatrix}$$

- Properties of affine transformations:
 - Origin does not necessarily map to origin
 - Lines map to lines
 - Parallel lines remain parallel
 - Ratios are preserved
 - Closed under composition

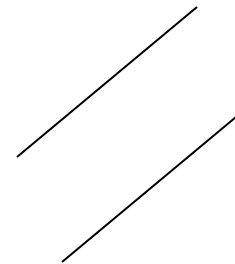

Projective Transformations

- Projective transformations ...
 - Affine transformations, and
 - Projective warps

$$\begin{bmatrix} x' \\ y' \\ w' \end{bmatrix} = \begin{bmatrix} a & b & c \\ d & e & f \\ g & h & i \end{bmatrix} \begin{bmatrix} x \\ y \\ w \end{bmatrix}$$

- Properties of projective transformations:
 - Origin does not necessarily map to origin
 - Lines map to lines
 - Parallel lines do not necessarily remain parallel
 - Ratios are not preserved (but “cross-ratios” are)
 - Closed under composition

Recap Example

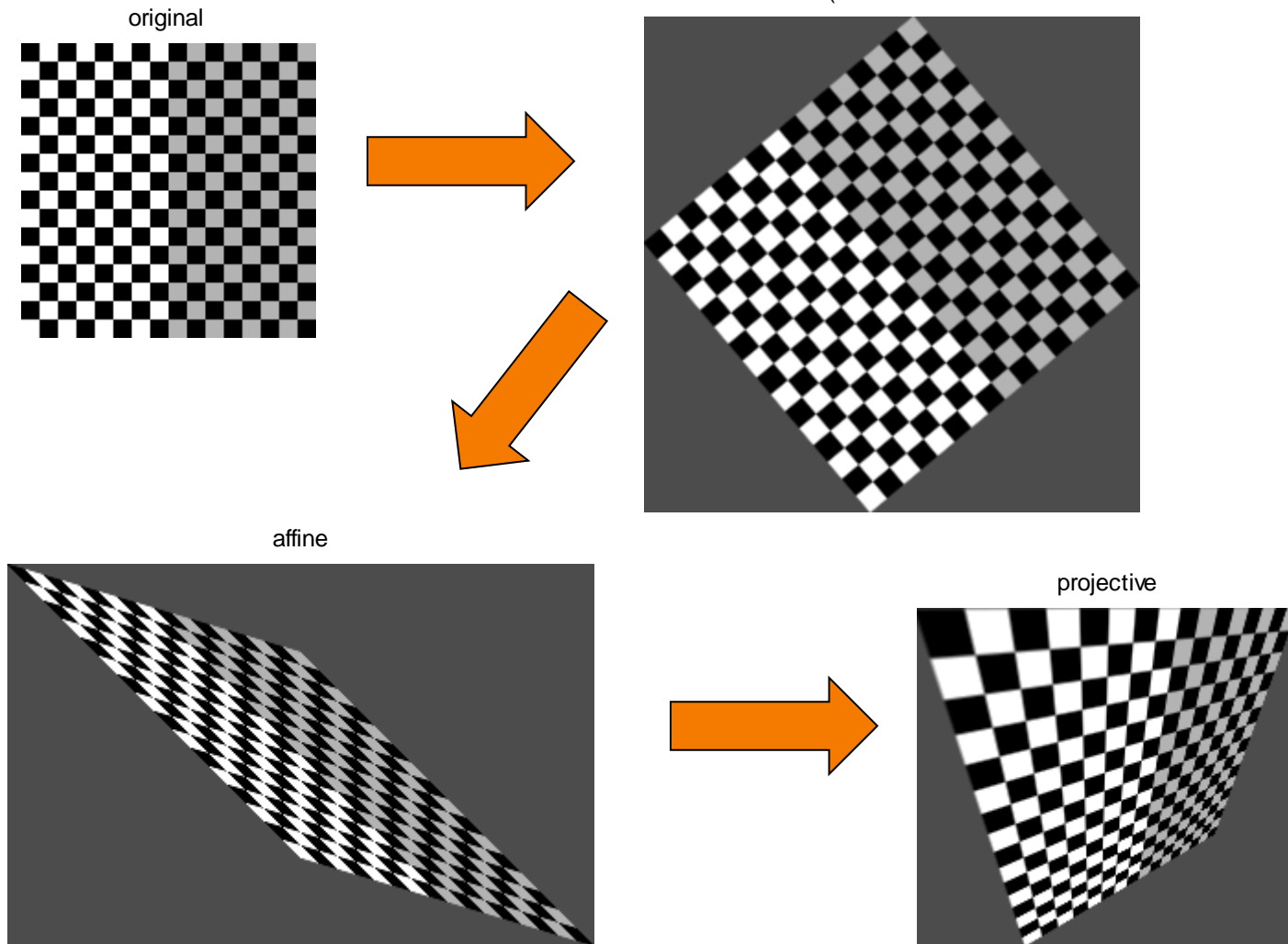

Recap Example

original



affine

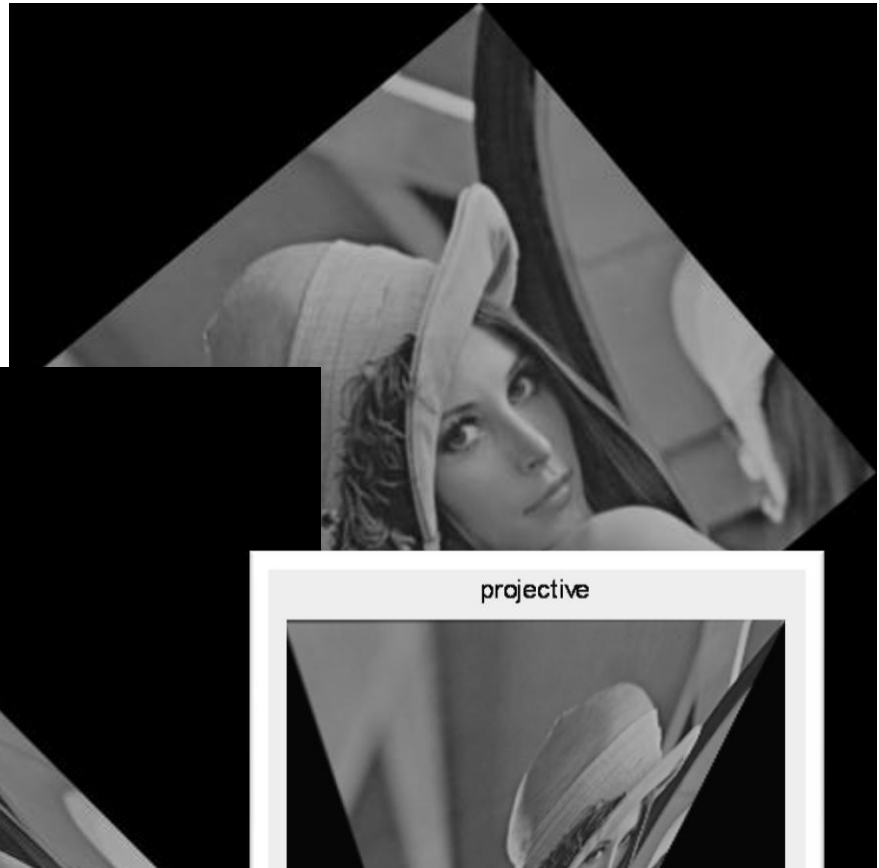

Linear (scale and rotation)

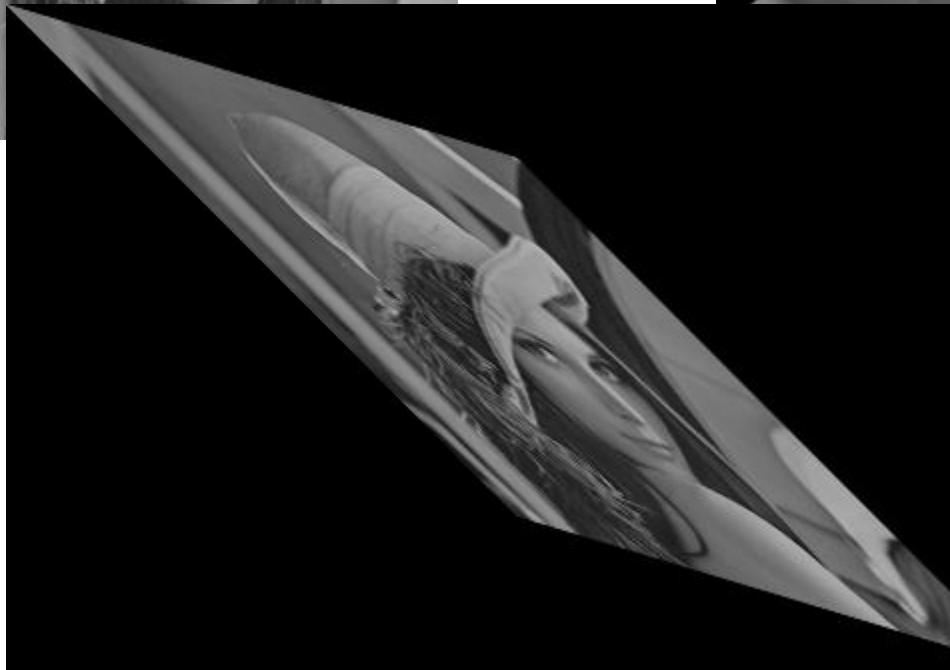

projective

Overview

- 2D Transformations
 - Basic 2D transformations
 - Matrix representation
 - Matrix composition
- 3D Transformations
 - Basic 3D transformations
 - Same as 2D
- Transformation Hierarchies
 - Scene graphs
 - Ray casting

Matrix Composition

- Transformations can be combined by matrix multiplication

$$\begin{bmatrix} x' \\ y' \\ w' \end{bmatrix} = \begin{pmatrix} \begin{bmatrix} 1 & 0 & tx \\ 0 & 1 & ty \\ 0 & 0 & 1 \end{bmatrix} \begin{bmatrix} \cos \Theta & -\sin \Theta & 0 \\ \sin \Theta & \cos \Theta & 0 \\ 0 & 0 & 1 \end{bmatrix} \begin{bmatrix} sx & 0 & 0 \\ 0 & sy & 0 \\ 0 & 0 & 1 \end{bmatrix} \end{pmatrix} \begin{bmatrix} x \\ y \\ w \end{bmatrix}$$

$$\mathbf{p}' = \mathbf{T}(tx,ty) \quad \mathbf{R}(\Theta) \quad \mathbf{S}(sx,sy) \quad \mathbf{p}$$

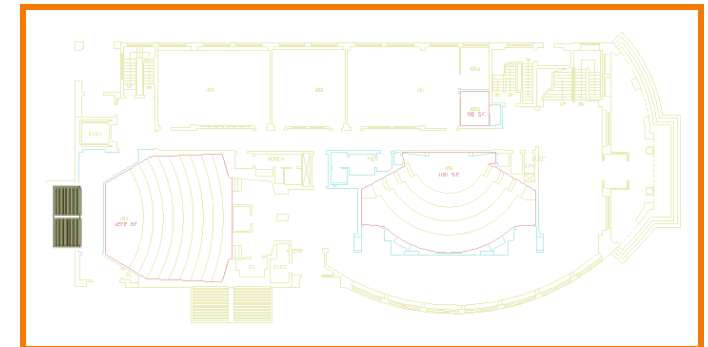

Matrix Composition

- Matrices are a convenient and efficient way to represent a sequence of transformations
 - General purpose representation
 - Hardware matrix multiply
 - Efficiency with premultiplication
 - Matrix multiplication is associative

$$\mathbf{p}' = (T * (R * (S * \mathbf{p})))$$
$$\mathbf{p}' = (T * R * S) * \mathbf{p}$$

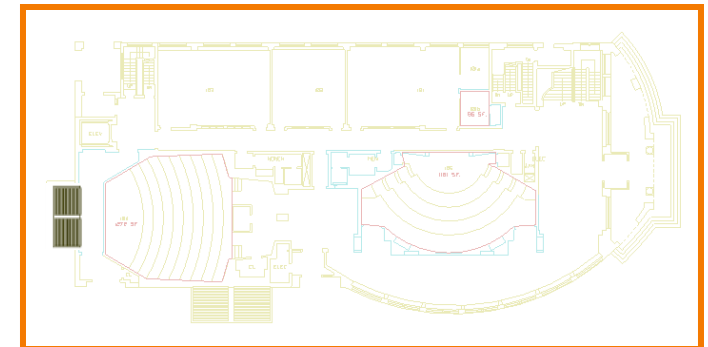

Matrix Composition

- Be aware: order of transformations matters
 - Matrix multiplication is not commutative

$$\mathbf{p}' = \mathbf{T} * \mathbf{R} * \mathbf{S} * \mathbf{p}$$

←—————→

“Global” “Local”

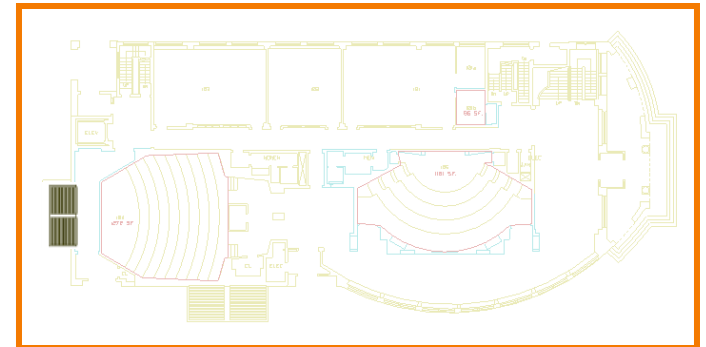

Matrix Composition

- Rotate by Θ around arbitrary point (a,b)
 - $M = T(-a,-b) * R(\Theta) * T(a,b)$

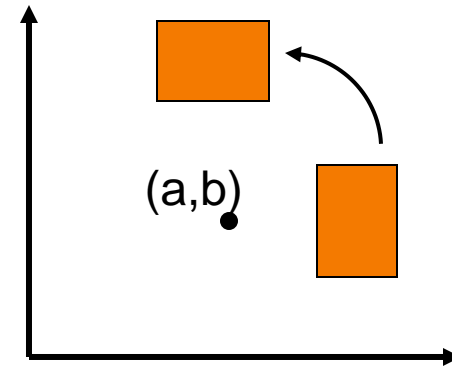

- Scale by s_x, s_y around arbitrary point (a,b)
 - $M = T(-a,-b) * S(s_x, s_y) * T(a,b)$

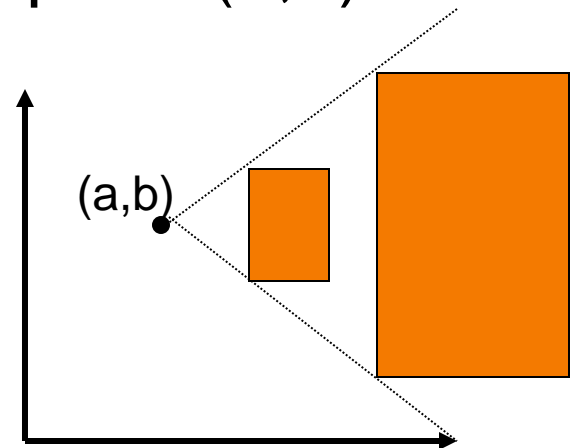

Overview

- 2D Transformations
 - Basic 2D transformations
 - Matrix representation
 - Matrix composition
- 3D Transformations
 - Basic 3D transformations
 - Same as 2D
- Transformation Hierarchies
 - Scene graphs
 - Ray casting

3D Transformations

- Same idea as 2D transformations
 - Homogeneous coordinates: (x,y,z,w)
 - 4x4 transformation matrices

$$\begin{bmatrix} x' \\ y' \\ z' \\ w' \end{bmatrix} = \begin{bmatrix} a & b & c & d \\ e & f & g & h \\ i & j & k & l \\ m & n & o & p \end{bmatrix} \begin{bmatrix} x \\ y \\ z \\ w \end{bmatrix}$$

Basic 3D Transformations

$$\begin{bmatrix} x' \\ y' \\ z' \\ w \end{bmatrix} = \begin{bmatrix} 1 & 0 & 0 & 0 \\ 0 & 1 & 0 & 0 \\ 0 & 0 & 1 & 0 \\ 0 & 0 & 0 & 1 \end{bmatrix} \begin{bmatrix} x \\ y \\ z \\ w \end{bmatrix}$$

Identity

$$\begin{bmatrix} x' \\ y' \\ z' \\ w \end{bmatrix} = \begin{bmatrix} sx & 0 & 0 & 0 \\ 0 & sy & 0 & 0 \\ 0 & 0 & sz & 0 \\ 0 & 0 & 0 & 1 \end{bmatrix} \begin{bmatrix} x \\ y \\ z \\ w \end{bmatrix}$$

Scale

$$\begin{bmatrix} x' \\ y' \\ z' \\ w \end{bmatrix} = \begin{bmatrix} 1 & 0 & 0 & tx \\ 0 & 1 & 0 & ty \\ 0 & 0 & 1 & tz \\ 0 & 0 & 0 & 1 \end{bmatrix} \begin{bmatrix} x \\ y \\ z \\ w \end{bmatrix}$$

Translation

$$\begin{bmatrix} x' \\ y' \\ z' \\ w \end{bmatrix} = \begin{bmatrix} -1 & 0 & 0 & 0 \\ 0 & 1 & 0 & 0 \\ 0 & 0 & 1 & 0 \\ 0 & 0 & 0 & 1 \end{bmatrix} \begin{bmatrix} x \\ y \\ z \\ w \end{bmatrix}$$

Mirror over X axis

Basic 3D Transformations

Rotate around Z axis:

$$\begin{bmatrix} x' \\ y' \\ z' \\ w \end{bmatrix} = \begin{bmatrix} \cos \Theta & -\sin \Theta & 0 & 0 \\ \sin \Theta & \cos \Theta & 0 & 0 \\ 0 & 0 & 1 & 0 \\ 0 & 0 & 0 & 1 \end{bmatrix} \begin{bmatrix} x \\ y \\ z \\ w \end{bmatrix}$$

Rotate around Y axis:

$$\begin{bmatrix} x' \\ y' \\ z' \\ w \end{bmatrix} = \begin{bmatrix} \cos \Theta & 0 & -\sin \Theta & 0 \\ 0 & 1 & 0 & 0 \\ \sin \Theta & 0 & \cos \Theta & 0 \\ 0 & 0 & 0 & 1 \end{bmatrix} \begin{bmatrix} x \\ y \\ z \\ w \end{bmatrix}$$

Rotate around X axis:

$$\begin{bmatrix} x' \\ y' \\ z' \\ w \end{bmatrix} = \begin{bmatrix} 1 & 0 & 0 & 0 \\ 0 & \cos \Theta & -\sin \Theta & 0 \\ 0 & \sin \Theta & \cos \Theta & 0 \\ 0 & 0 & 0 & 1 \end{bmatrix} \begin{bmatrix} x \\ y \\ z \\ w \end{bmatrix}$$

Overview

- 2D Transformations
 - Basic 2D transformations
 - Matrix representation
 - Matrix composition
- 3D Transformations
 - Basic 3D transformations
 - Same as 2D
- Transformation Hierarchies
 - Scene graphs
 - Ray casting

Transformation Hierarchies

- Scene may have hierarchy of coordinate systems
 - Each level stores matrix representing transformation from parent's coordinate system

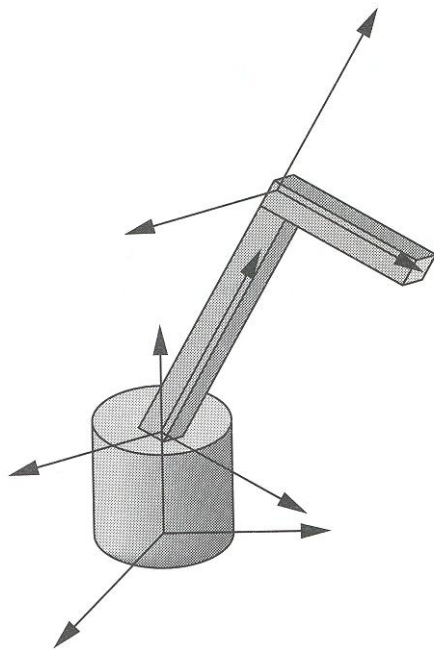

Robot Arm

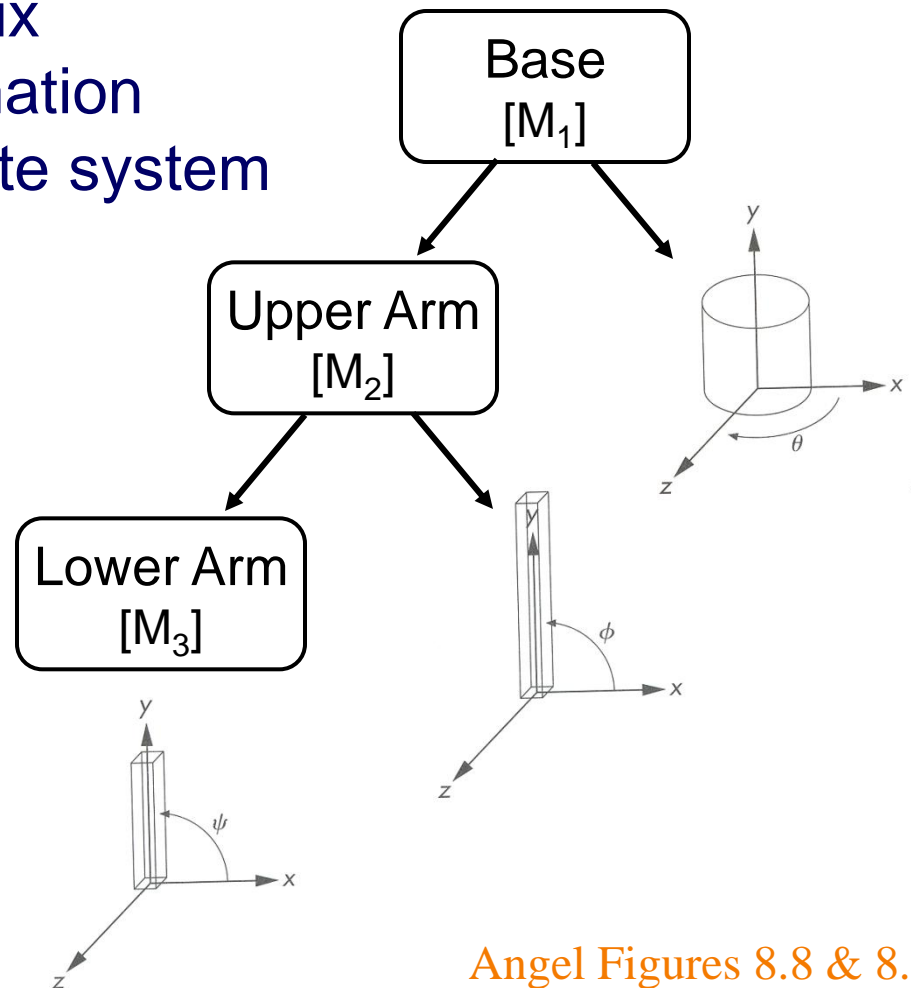

Angel Figures 8.8 & 8.9

Transformation Example 1

- Well-suited for humanoid characters

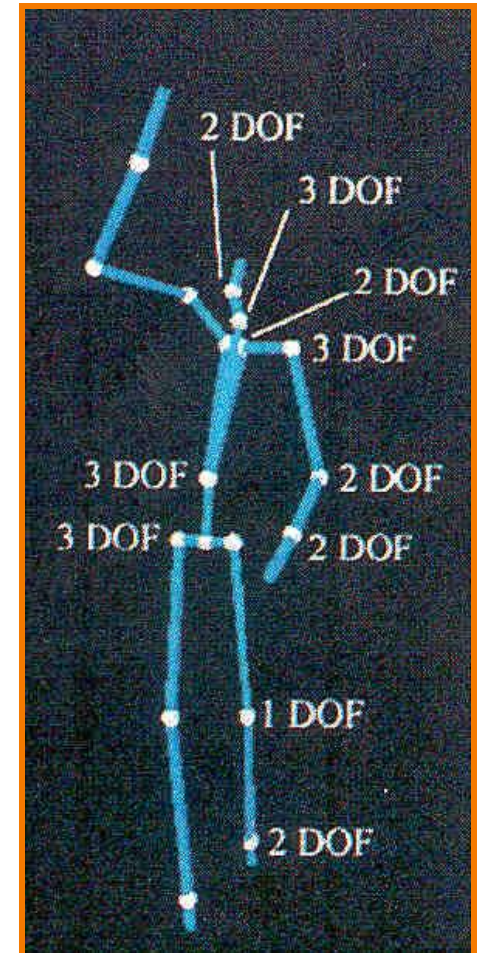
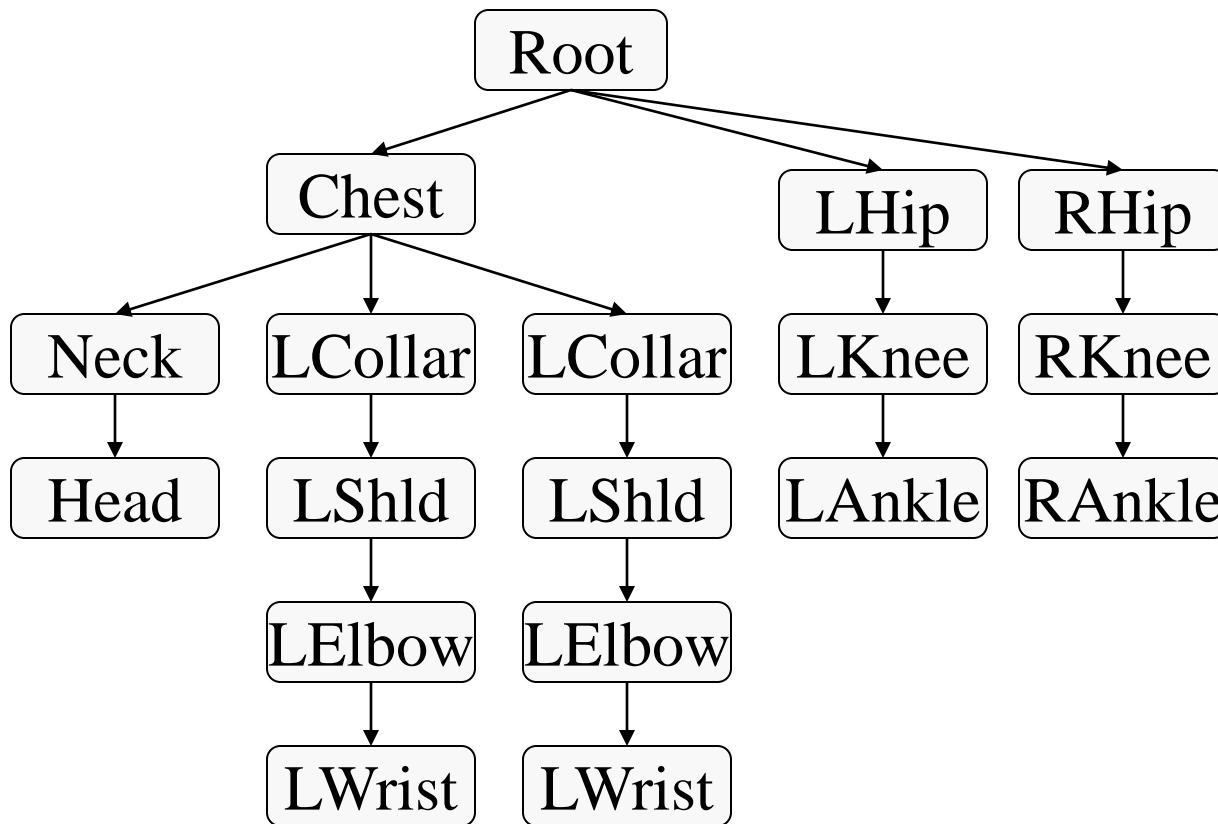

Rose et al. '96

Transformation Example 1



Mike Marr, COS 426,
Princeton University, 1995

Transformation Example 2

- An object may appear in a scene multiple times

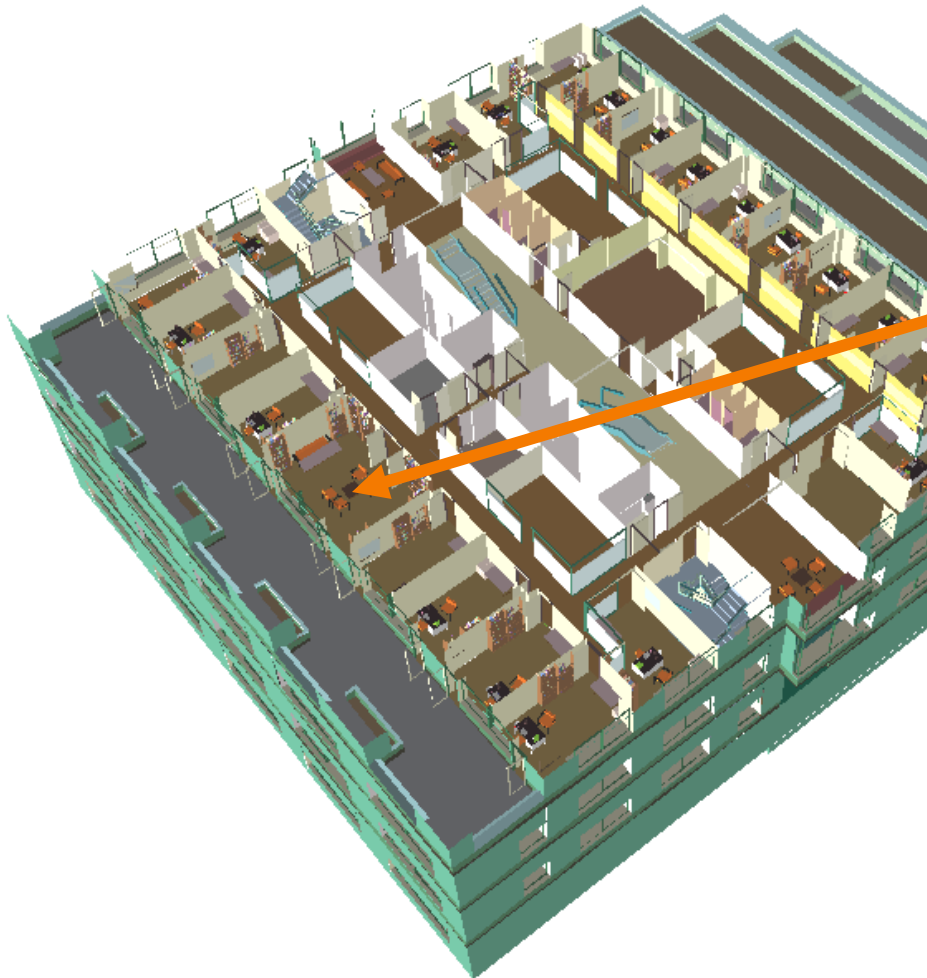

Draw same 3D data with different transformations

Transformation Example 2

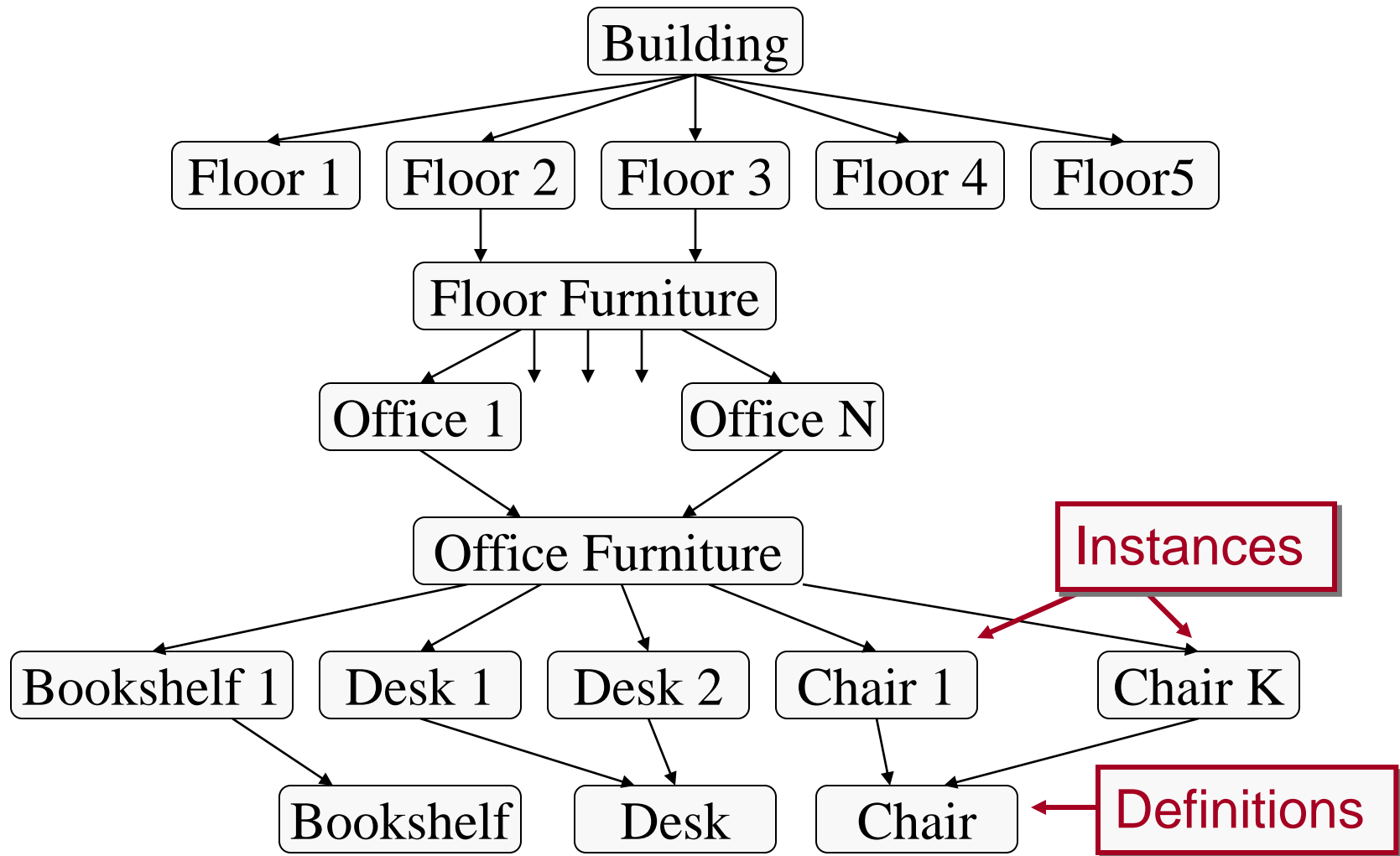

Summary

- Coordinate systems
 - World coordinates
 - Modeling coordinates
- Representations of 3D modeling transformations
 - 4x4 Matrices
 - Scale, rotate, translate, shear, projections, etc.
 - Not arbitrary warps
- Composition of 3D transformations
 - Matrix multiplication (order matters)
 - Transformation hierarchies

Next time

- Views, Projections and Ray Casting

