

## ECSAM MODEL COMPONENTS

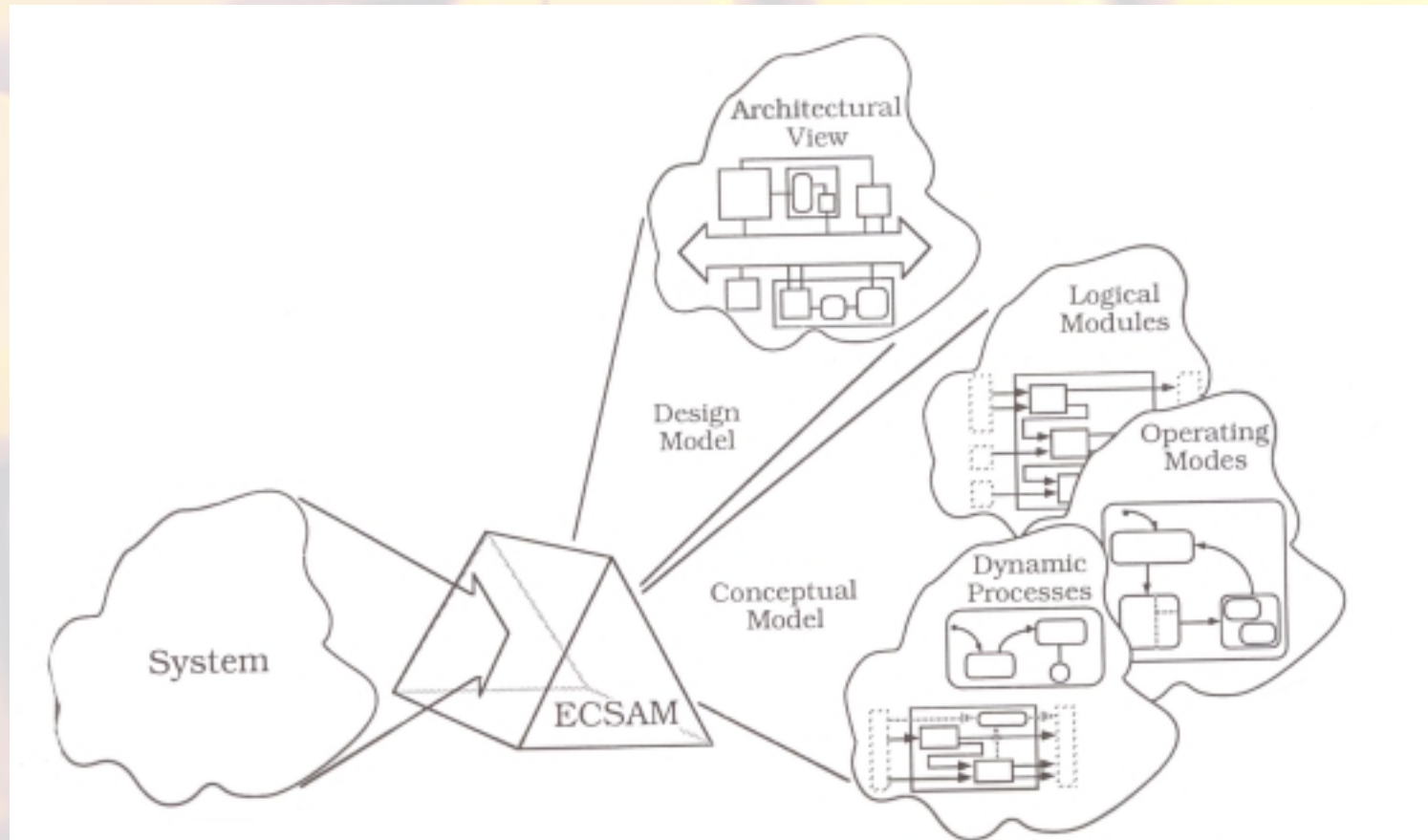

# ECSAM DESCRIPTION OF MULTI-LEVEL SYSTEMS

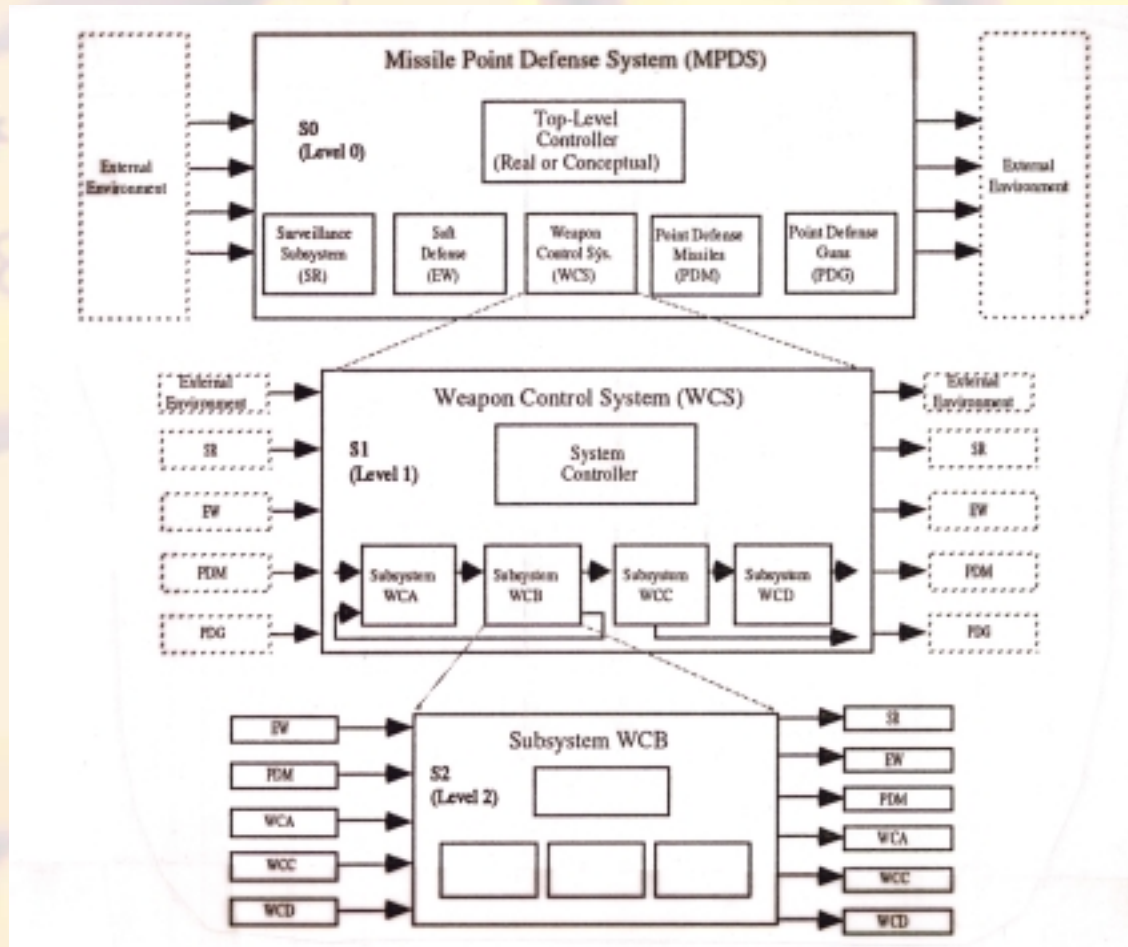

## EXAMPLE - REMOTELY PILOTED AIR - VEHICLE (RPAV)

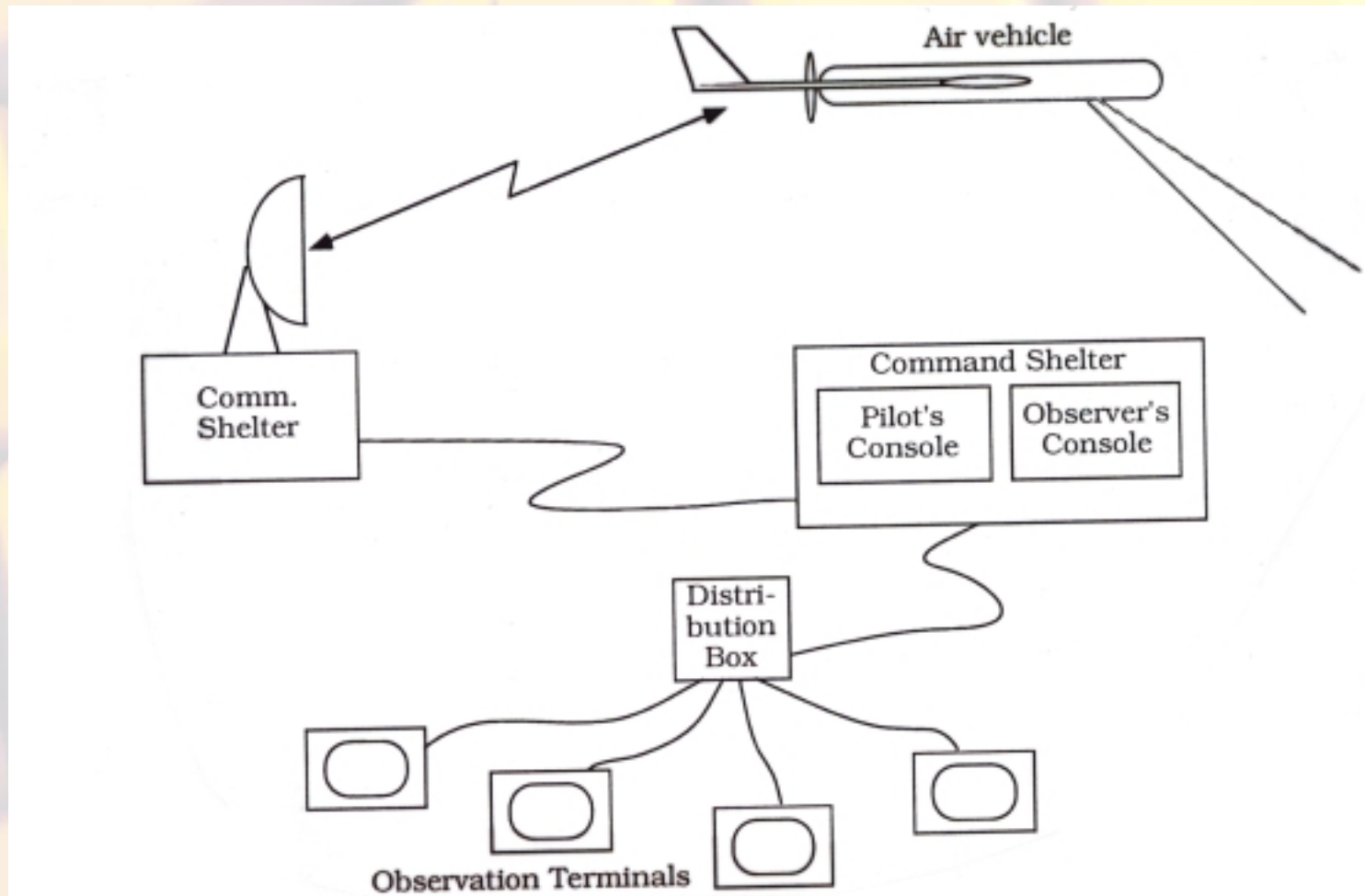

## EXAMPLE - REMOTELY PILOTED AIR - VEHICLE CONCEPTUAL SUBSYSTEMS

